



DOI: 10.34910/MCE.104.3

Deflection of a cladding panel of fully tempered glass in curtain wall system

E. Gerasimova^{*a}, A. Galyamichev^b, G. Schwind^c, J. Schneider^c

^a NIUPC «Mezhregional'nyj institut okonnyh i fasadnyh konstrukcij», St. Petersburg, Russia

^b Peter the Great St. Petersburg Polytechnic University, St. Petersburg, Russia

^c Technical University of Darmstadt, Darmstadt, Germany

*E-mail: katyageras17@gmail.com

Keywords: facade, cladding, glass, aluminum, substructure, sealant

Abstract. The article presents a study on the mechanical behavior of facade cladding panel consisting of aluminum frame and fully tempered sheet glass under the action of uniformly distributed load. The study involved tests of full-size samples of two structural solutions of the cladding panel in a curtain wall system for two different geometrical configurations of the panel. Experimental data showed a high similarity with the results of a static calculation in the zone of linear elastic deformation. Therefore, the use of SJ Mepla finite element software package for the calculation of described structures was verified. The influence of the boundary conditions on determination of deflections in numerical model as well as the character of seal deformation was described. The criteria of the loss of bearing capacity of a system was defined. Empirical formulas for calculating the panel deflection for specific geometrical configurations of a panel were proposed.

1. Introduction

Nowadays glass is widely used as a main translucent material of the building enclosing structures due to its structural and aesthetical advantages and unique properties [1, 2]. Besides the mullion-transom and structural glass facades, curtain wall systems with glass panels as a cladding material are actively used in modern construction practice. These systems are characterized by faster installation in comparison with other glazing systems and offer aesthetical benefits.

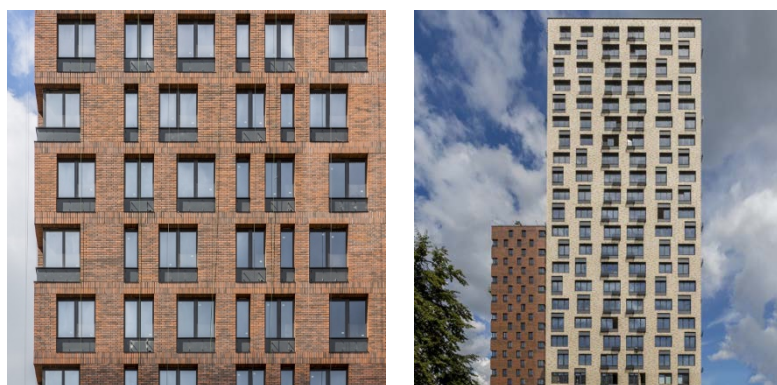

Figure 1. Example of glass cladding in curtain wall systems – residential complex “Petrovsky” (source: Official website of the manufacturer of facade system www.nordfox.ru).

The choice of facade structure directly affects the safety and comfort of people inside the building [3, 4]. In [5] a study on the influence of the glass fixing type on the fire resistance of structure is presented. Article [6] is devoted to an analysis of the stress-strain state of curtain wall systems under extreme loads



such as natural exposures and man-made threats. The correlation between characteristics of the glass and performance of double-glazed facades is described in [7].

Modern glazing systems can be classified on the base of different criteria [8]. One of the factors which determines the overall performance of a system is method of fixing of a glass panel to the substructure [9–11]. The dependence of the fixing method on the strength of glass is studied in [12]. In [13] an analysis of existing design guidelines and methods intended for calculation of glass fencing, which is fixed in an aluminum profile, is presented. Application and experimental verification of glass fencing system are also presented. According to [13], the stiffness of the clamping profile and the choice of approach among different methods proposed in regulatory documents (e.g. national building codes) have the greatest impact on the calculation result. At the same time, the calculation procedures need to be improved, since they are not adapted for the fence fixed in the curtain wall system. A study on the aluminum-and-glass facades is presented in [14]. The study in [14] contains investigation on various systems in order to verify their economic viability and possibility of use in modern construction.

Due to increased requirements for the heat transfer through building envelope [15, 16], parameters of curtain wall systems are actively reconsidered [17]. Modeling approach for climatic simulation of curtain facades is described in [18]. The study on the influence of orientation of buildings with glass facades on its energy consumption is presented in [19].

In [20] simulations were performed in order to assess the mechanical behavior of panels with direct glass-aluminum connection. The numerical study in [20] is particularly focused on the influence of elastic layer (rubber spacers or glue layers) on improvement of working conditions of the glass-aluminum connections. The study in [21] is devoted to the determination of partial material safety factor for structural silicone adhesives. Obtained on the base of experimental data, this value can be applied in finite element calculation programs, leading to the optimization of structural sealant design.

The use of glass beads in facade systems raises the issues related with tightness of the joint. Experimental study on the tightness of glazing bead butt joints of aluminum windows was performed in [22].

Experimental and numerical investigation of the properties and possibilities of application of structural sealants in glazing systems is described in [23]. Issues related to the modeling and fracture analysis of sealants are observed in [22–25].

Facade structures face various exposures during its operational lifetime, however in absence of thermal loading the wind load represents the highest contribution to the stress-strain state of the members of facade system. Lateral loads (e.g. wind) are prevalent and require detailed consideration in accordance with local climate conditions during the process of design and calculation of such structures [28].

In this research, the object of the study was a fully tempered sheet glass in a specific aluminum frame as the cladding of curtain facade system. Within the study both experimental and numerical analysis of the cladding of a curtain wall system were performed.

The purpose of the study was determination of the deflection of a cladding panel within the fixing system of a curtain wall.

The following tasks were carried out:

- Experimental determination of deflection of a cladding panel of fully tempered sheet glass, fixed to a curtain wall system, under the action of a uniformly distributed load;
- Determination of the influence of the geometric dimensions on the deflection of a panel;
- Determination the criteria characterizing loss of bearing capacity of the system;
- Comparison of results of the panel's stress-strain state obtained through numerical methods and laboratory tests.

2. Methods

The study contains experimental and numerical investigation of a full-size fragment of a considered curtain wall system. A glass cladding panel was continuously fixed to the aluminum frame through a glass bead what represents a particular case of clamped solution. Furthermore, two different fixation schemes were performed:

- Test setup 1: Cladding panel of fully tempered sheet glass is 2-side simply supported (Navier's support) by glazing beads and frame through the EPDM profiles. Glazing bead and a frame thus form a compound profile. This profile is supported on its edges by self-tapping screws which attach it to the transom.

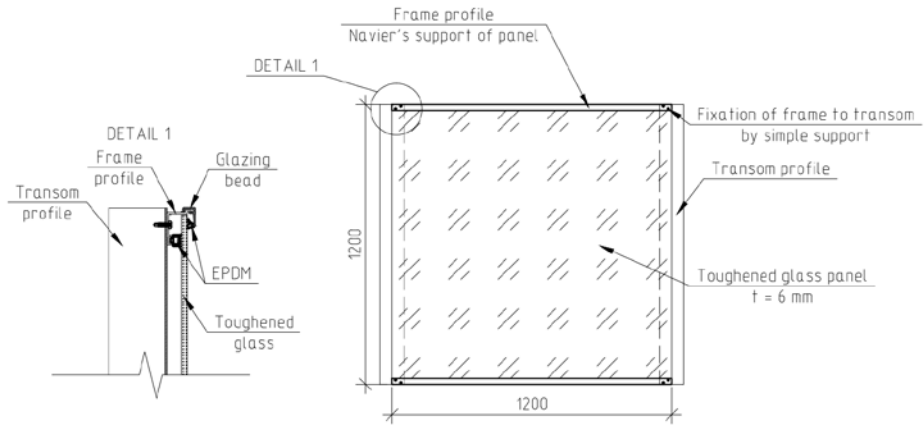

Figure 2. Scheme of system type 1 (test setup 1).

- Test setup 2: Cladding panel of fully tempered sheet glass is 2-side simply supported (Navier's support) by glazing beads and frame through the EPDM profiles. Frame profile is discretely supported along its entire length by self-tapping screws which attach it to the transom. Glazing bead, a frame and transom thus form a compound profile of a higher stiffness than test setup 1.

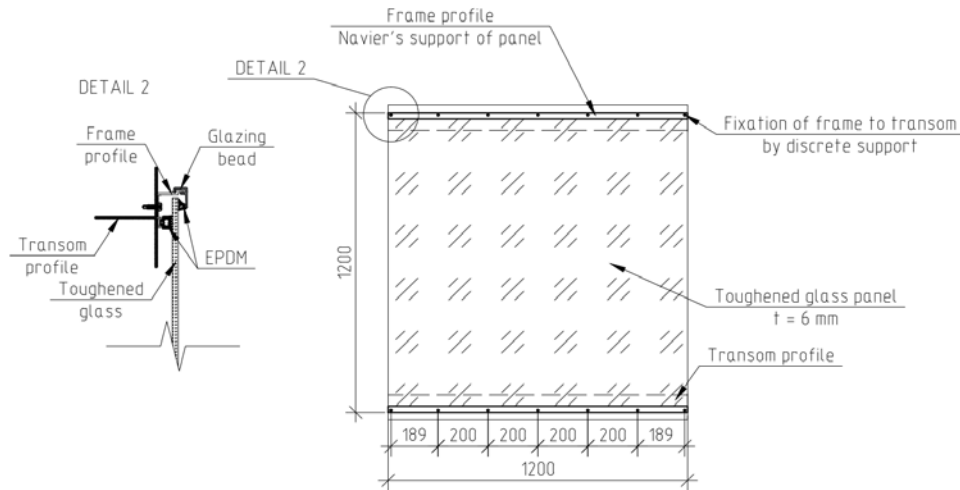

Figure 3. Scheme of system type 2 (test setup 2).

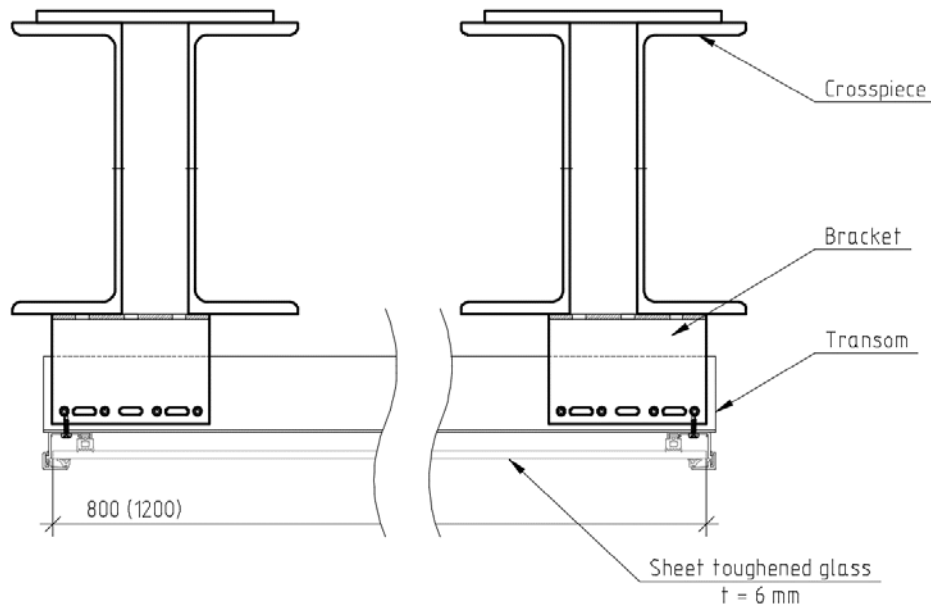

Figure 4. Cross-section of the test setup 2.

The experiments were performed for two different configurations of cladding panels: 1200x1200 mm and 1200x800 mm.

Fully tempered glass for all considered schemes had a thickness of 6 mm. According to Russian State Standard GOST 30698-2014 «Tempered glass. Specifications», fully tempered glass has a bending strength of 120 MPa.

All the aforementioned geometrical values were measured during the test.

Therefore, following schemes were considered:

- Test setup 1a: 1200x800x6 mm;
- Test setup 1b: 1200x1200x6 mm;
- Test setup 2a: 1200x800x6 mm;
- Test setup 2a: 1200x1200x6 mm.

2.1. Experimental approach

The purpose of the testing was an experimental determination of the deflections of the curtain wall system in characteristic points: in the center of the panel, center of the free edge and center of the frame profile. The obtained results were subsequently compared to the results of numerical calculation.

Determination of the cladding panel's deflection was carried out by means of a full-size simulation of a frame fragment of the curtain wall system and its subsequent loading with a uniformly distributed load. Special high rigidity crosspieces with brackets mounted to them in the horizontal plane were used as a bearing base in test setup.

The use of horizontal arrangement of the panels was justified by the convenience of testing, as well as by the small influence of loads in the plane of the facade on the stress-strain state of the system [29]. The uniformly distributed load on the cladding panels was applied by means of concrete cores with a diameter of 150 mm, height of 150 mm and an average weight of 6.22 kg each. The cores were distributed on the surface of the panel evenly and symmetrically with respect to the center of the glass plate. The order of applying the load is chosen with the purpose to achieve a load value of approximately 1 kN/m² with subsequent unloading for the purpose of detecting backlash and crumples in the areas where the bracket is fixed through rivet connection. The assumption of value of 1 kN/m² for the purpose of detecting backlash is based on previous preliminary studies made by authors which were performed for various facade structures. Furthermore, loading with concurrent deflection control was continued until the loss of the bearing capacity of the system.

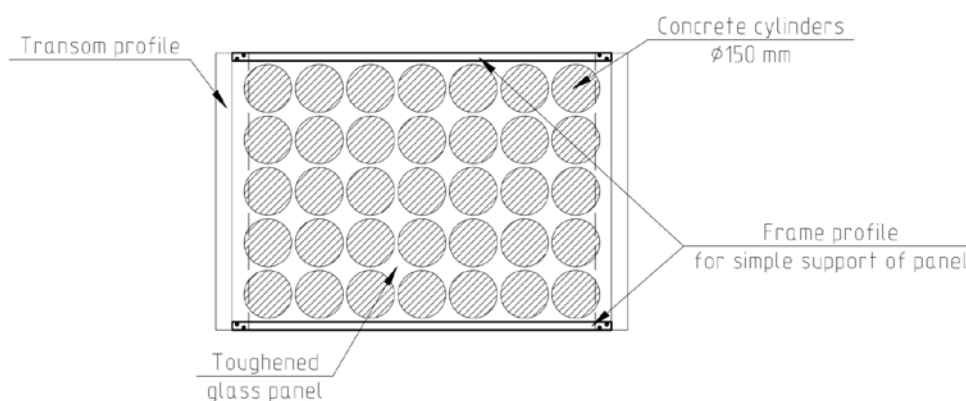

Figure 5. Principal loading scheme (test setup 1a).

The values of deflection in the center of the panel, center of the free edge and center of the frame profile were measured by dial indicators 6-PAO with following characteristics:

- Graduation: 0.01 mm;
- Maximum value of measurement: 100 ± 0.5 mm;
- Accuracy in the interval [0...1 mm]: ± 0.03;
- Accuracy in the interval [0...10 mm]: ± 0.3.

Location of dial indicators (DI) is shown in Fig. 6.

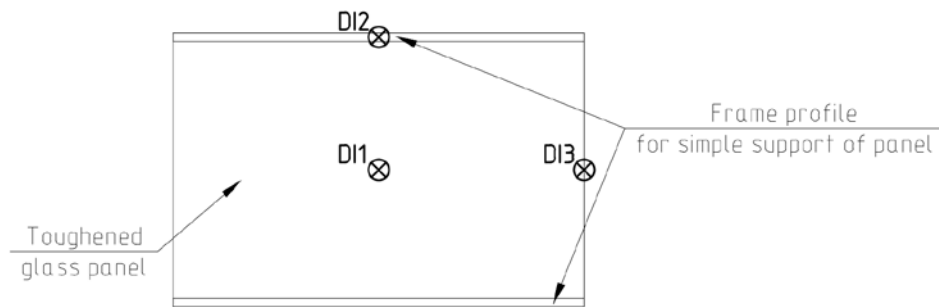

Figure 6. Location of dial indicators for measurement of the deflections for test setup 1 and 2.

Values obtained from dial indicators were processed in Excel and resulting deflections for each step of loading were obtained.

Tests were carried out on the two identical samples of each structural scheme.



Figure 7. Experimental setup – test setup 1.

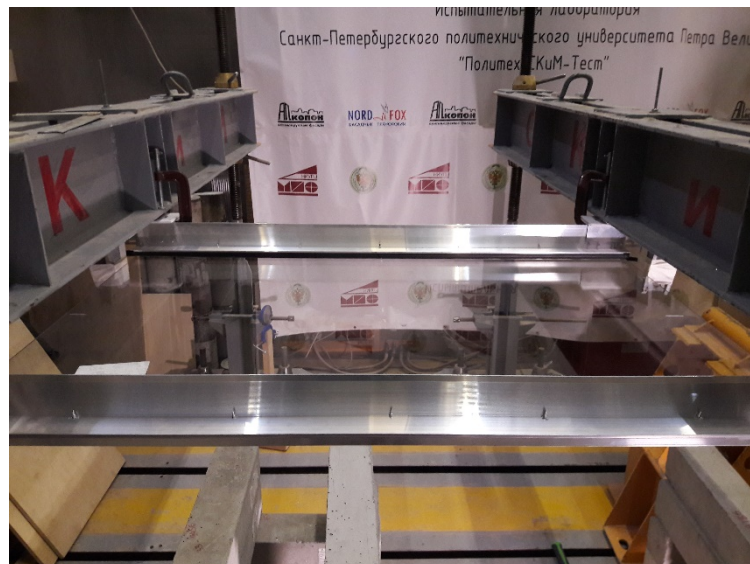

Figure 8. Experimental setup – test setup 2.

2.2. Numerical approach

The fragment of considered curtain wall system was modeled in finite element software package in accordance with schemes shown in Fig. 2 and 3 and experimental setup. Values of deflection in the same characteristic points of curtain wall system were obtained for the further analysis.

The considered elements were rectangular homogeneous isotropic flexible plates of a large deflection, where two parallel sides are simply supported with a stiffness defined by configuration of the aluminum profiles. The other two sides of glass plates are free.

Flexible plates of a large deflection are the plates, which are thin to that extend that the membrane stresses arising in them can have a noticeable effect on the deflections under an action of a transverse load. At the same time, these plates bend so significantly that the influence of their deflection on the value of the efforts striving to cause deformation of their middle layer cannot be neglected. The calculation of flexible plates of large deflection is based on the use of the system of differential equations describing bending and tensile deformations. In this study, the Finite Element Method (FEM) based on the theory of thin plates and realized in software SJ Mepla version 4.0.6 was used for the calculation of the plates fixed in aluminum profiles. Basic isoparametric finite element included 9 nodes and was created by means of interpolation functions in Lagrange form.

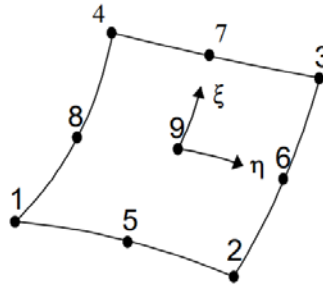

Figure 9. 9-nodes finite element.

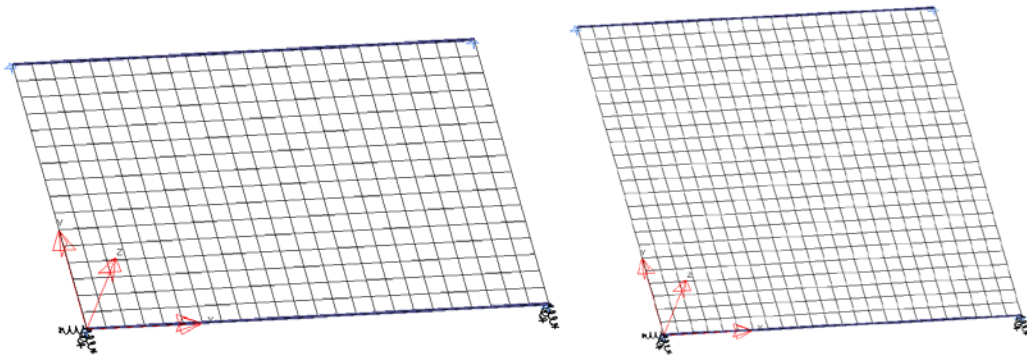

Figure 10. Finite element models of panels (maximum size of mesh element is 50 mm).

Curtain wall system of test setup 1 can be interpreted as follows:

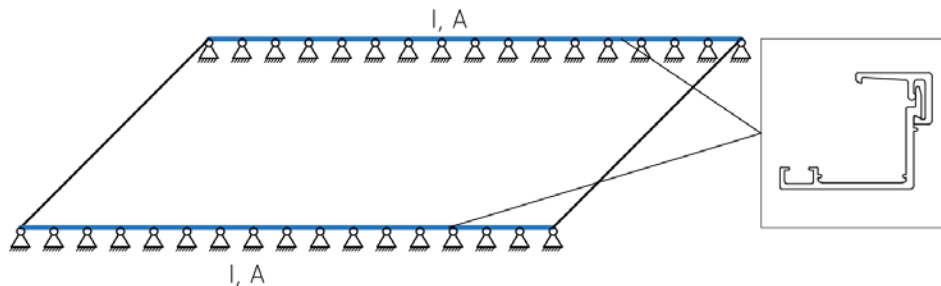

Figure 11. Principal structural scheme of test setup 1 (simple supports refer to the fixation of glass).

Curtain wall system of test setup 2 can be interpreted as follows:

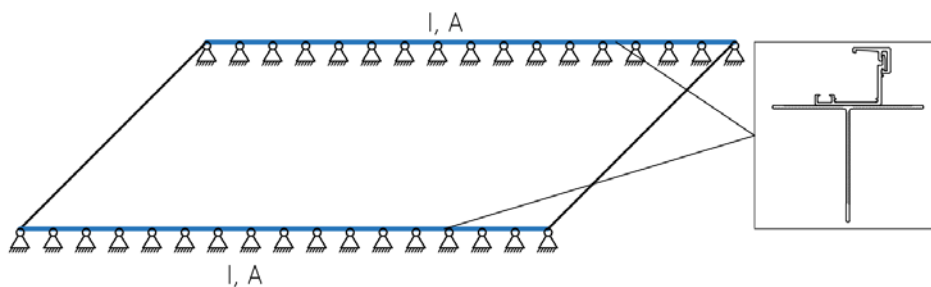

Figure 12. Principal structural scheme of test setup 2 (simple supports refer to the fixation of glass).

The finite element model assumed the direct interaction between aluminum profiles and glass panel.

For ease of calculation the mechanical behavior of EPDM was not accounted in numerical model at this stage of research.

Correct static calculation required considering the stiffness of aluminum transoms installed along two parallel sides of the panel:

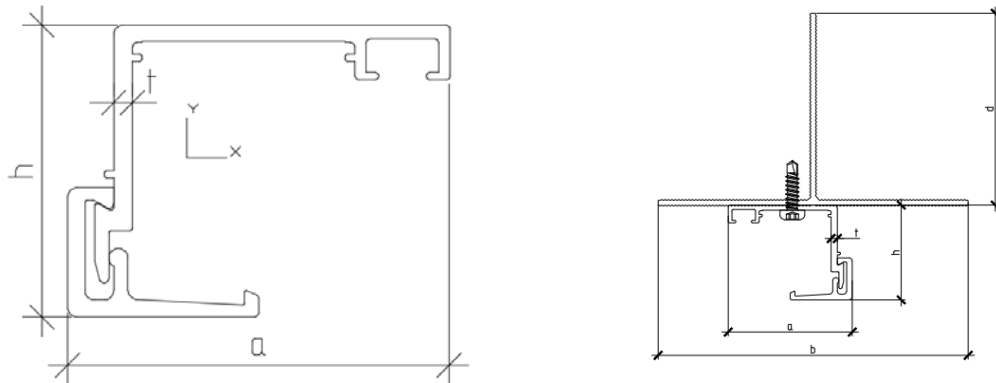

Figure 13. Left – transom profile of test setup 1; right – transom profile of test setup 2.

Stiffness characteristics of aluminum used in the study are presented below. The values were obtained in Consul, a satellite of SCAD Office software.

Modulus of elasticity:

$$E_{\text{aluminum}} = 70 \text{ GPa} .$$

Poisson's ratio:

$$\nu_{\text{aluminum}} = 0.3 .$$

Table 1. Geometric characteristics of transom profile of test setup 1.

A	Area of cross-section	1.912	cm ²
I_x	Moment of inertia about the central axis X1 parallel to the axis X	2.542	cm ⁴
I_y	Moment of inertia about the central axis Y1 parallel to the axis Y	2.501	cm ⁴
I_t	Free torsion moment of inertia	0.019	cm ⁴
I_p	Polar moment of inertia	5.043	cm ⁴

Table 2. Geometric characteristics of transom profile of test setup 2.

A	Area of cross-section	4.75	cm ²
I_y	Moment of inertia about the central axis Y1 parallel to the axis Y	20.208	cm ⁴
I_y	Moment of inertia about the central axis Y1 parallel to the axis Y	20.941	cm ⁴
I_t	Free torsion moment of inertia	0.064	cm ⁴
I_p	Polar moment of inertia	40.63	cm ⁴

3. Results and Discussion

Results obtained during numerical calculations and experiments demonstrate that curtain wall system of test setup 2 has a higher overall stiffness in comparison with test setup 1. The profiles in test setup 1 turn as the panel bends under the action of uniformly distributed load on the panel. The angle of inclination of clamped edge of a glass panel is proportional to the load value, profile's stiffness and size of the panel. The profiles in test setup 2 resist turning due to the fact of discrete connection to the transom. Fig. 14 shows the results determined with SJ Mepla of the rotation at the support due to the load.

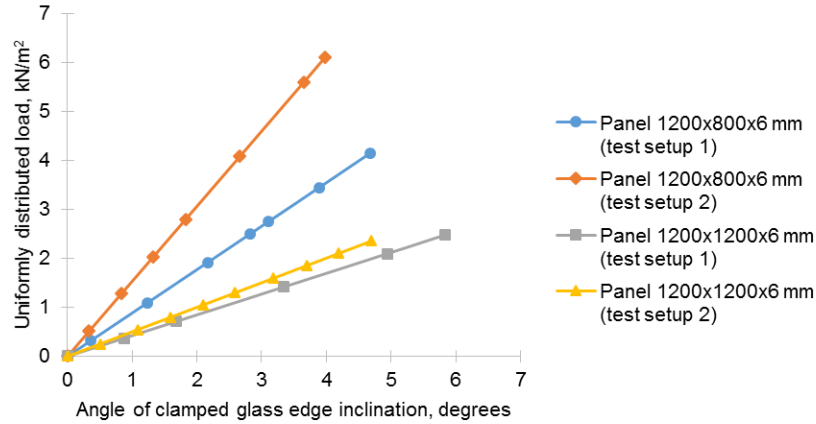

Figure 14. Dependence between inclination of clamped glass edge and value of uniformly distributed load.

Rotation of profiles impacts its geometrical characteristics. Fig. 15 shows how the moment of inertia of the profiles changes as a function of rotation. Therefore two types of numerical models were considered during static calculation: in the first option the moment of inertia as a characteristic of support conditions is set constant while in the second option the moment of inertia is variable and refers to the value of face load.

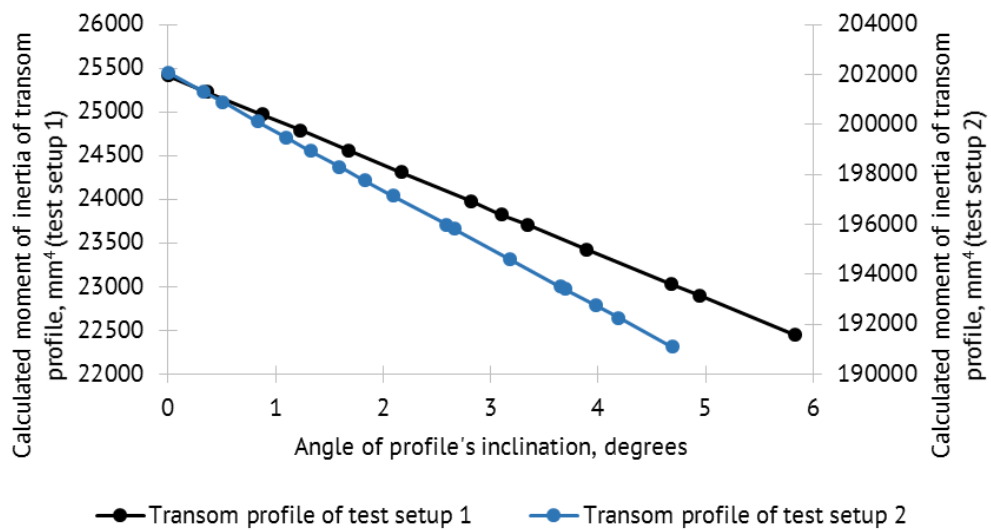

Figure 15. Dependence between inclination of the profile and profile's moment of inertia.

The results of tests performed on two samples of each structural scheme were compared to the results of static calculation in SJ Mepla. Two types of models were calculated: with constant and variable moment of inertia of profiles.

Test setup 1a: Comparison between experimental and numerical determined results

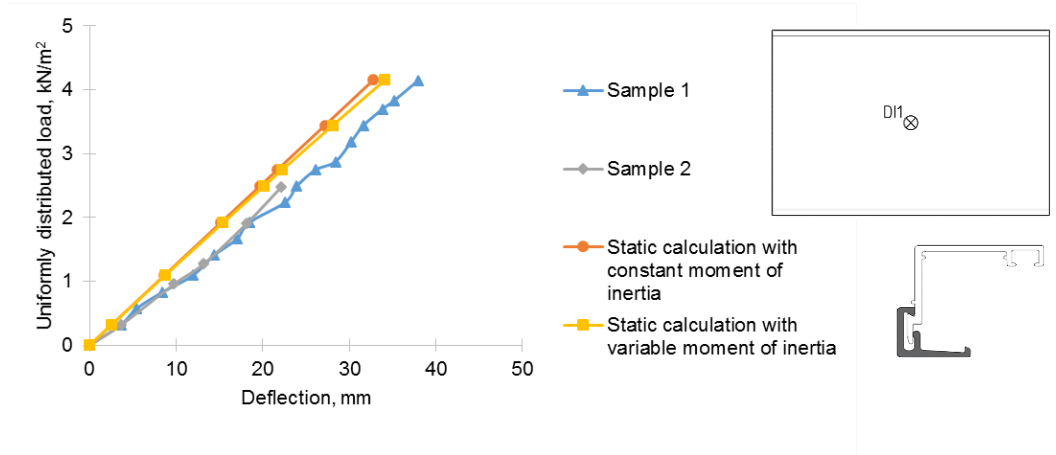

Figure 16. Deflection of the center of the panel (DI1).

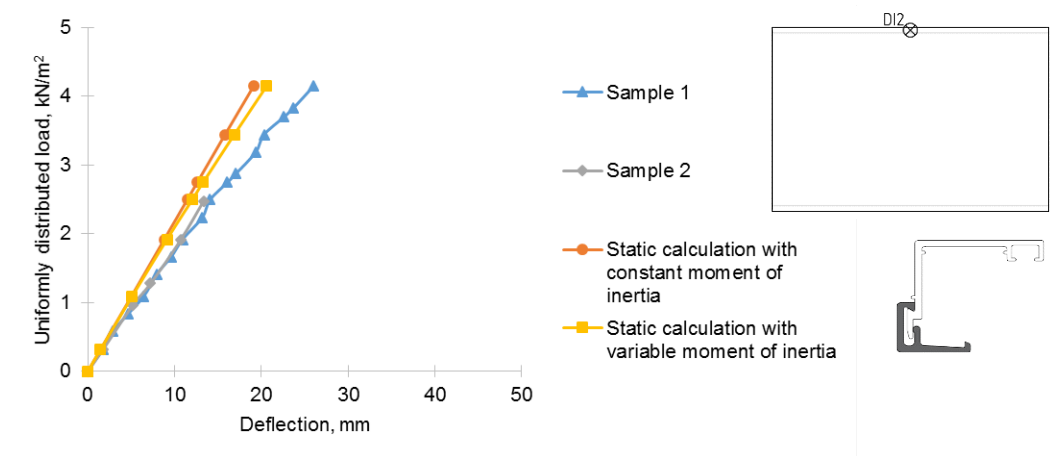

Figure 17. Deflection of the center of the frame (DI2).

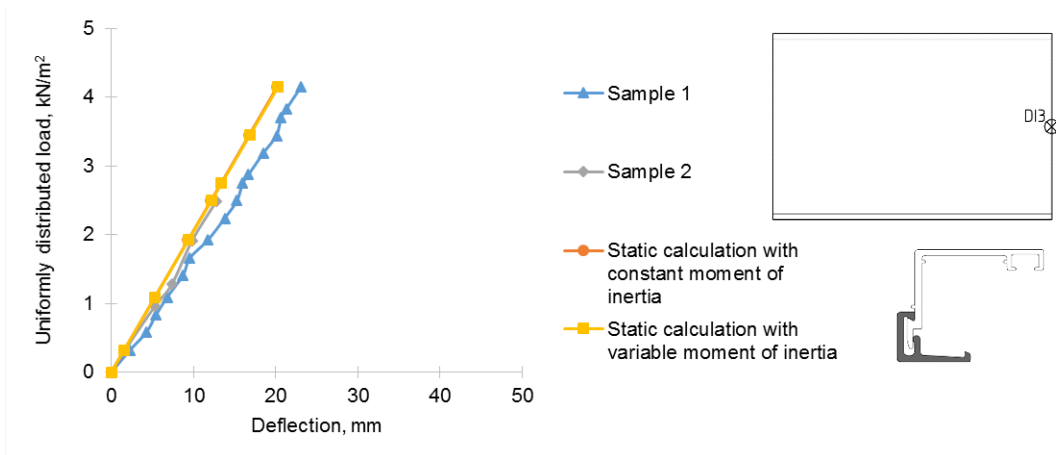

Figure 18. Deflection of the panel edge (DI3).

Test setup 2a: Comparison between experimental and numerical determined results

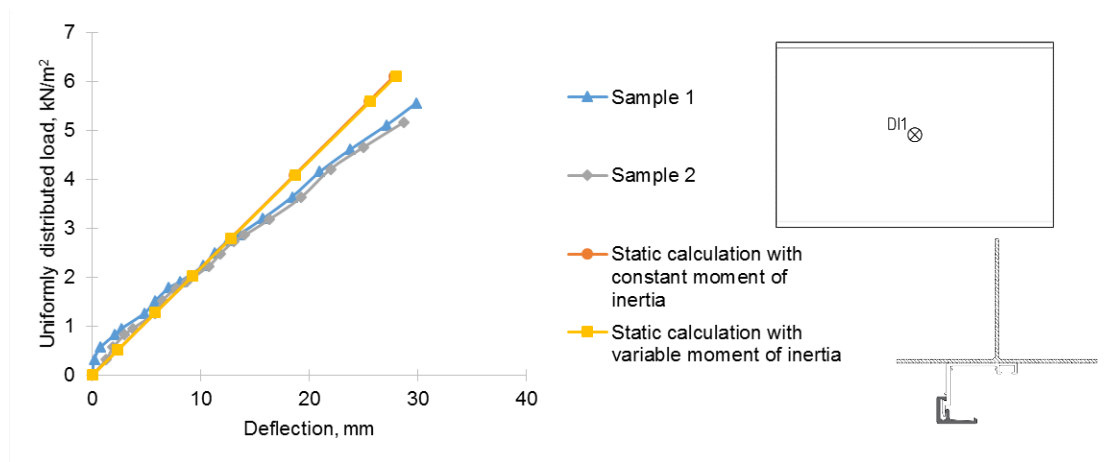

Figure 19. Deflection of the center of the panel (DI1).

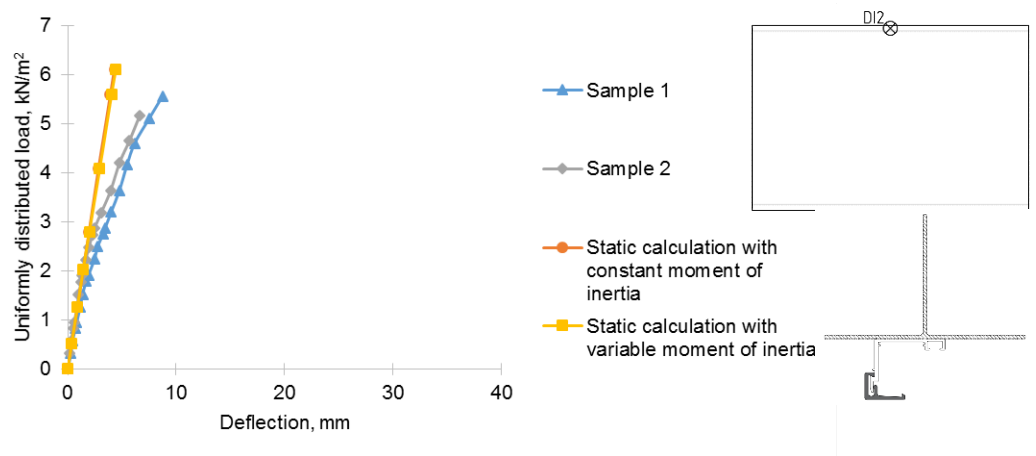

Figure 20. Deflection of the center of the frame (DI2), position of DI, section of edge beam.

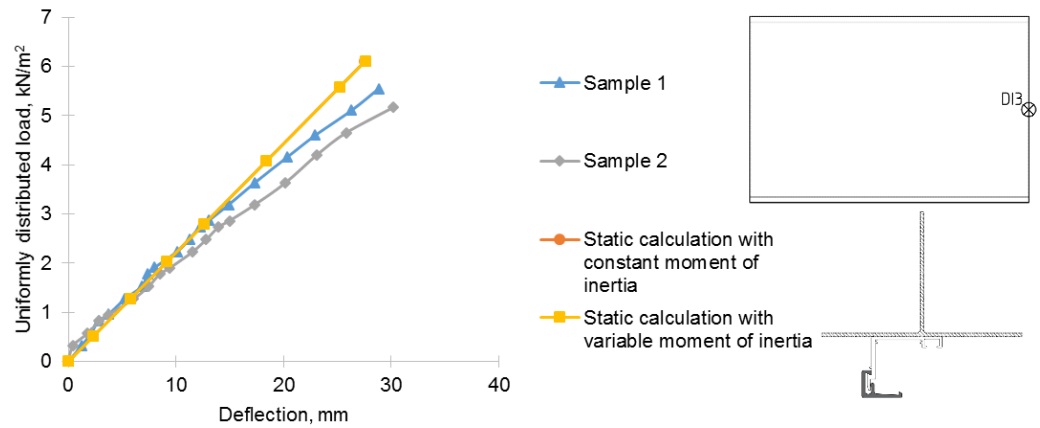

Figure 21. Deflection of the panel edge (DI3).

Test setup 1b: Comparison between experimental and numerical determined results

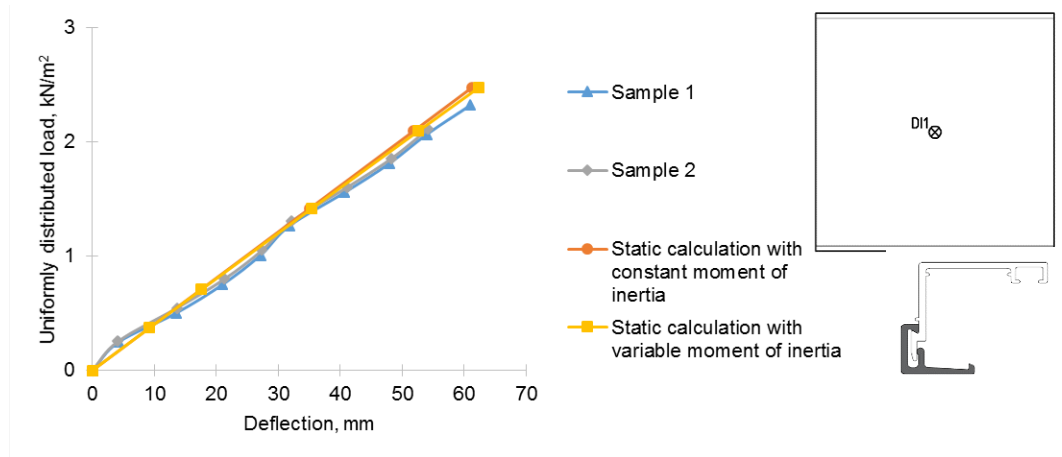

Figure 22. Deflection of the center of the panel (DI1).

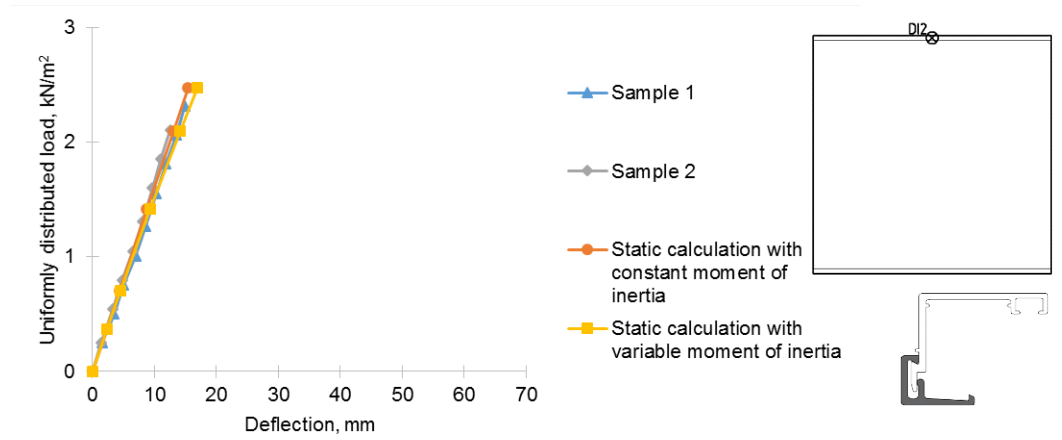

Figure 23. Deflection of the center of the frame (DI2).

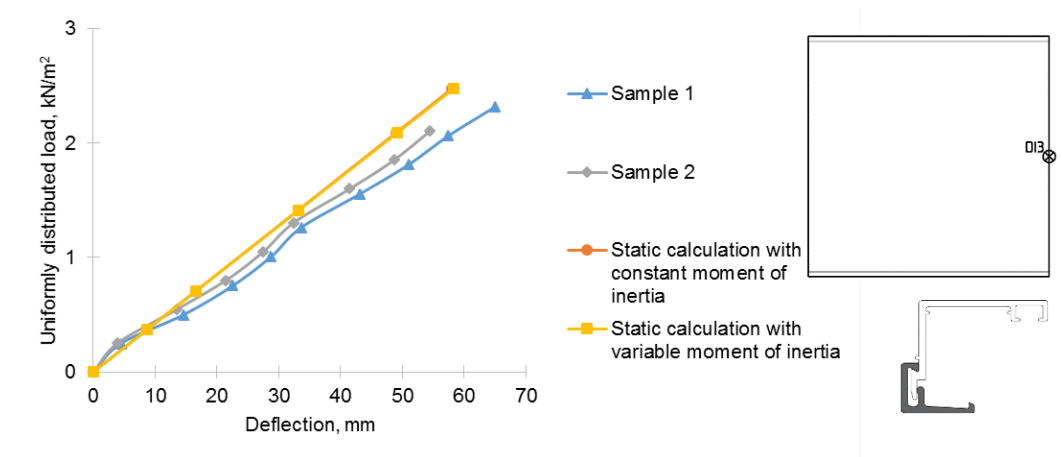

Figure 24. Deflection of the panel edge (DI3).

Test setup 2b: Comparison between experimental and numerical determined results

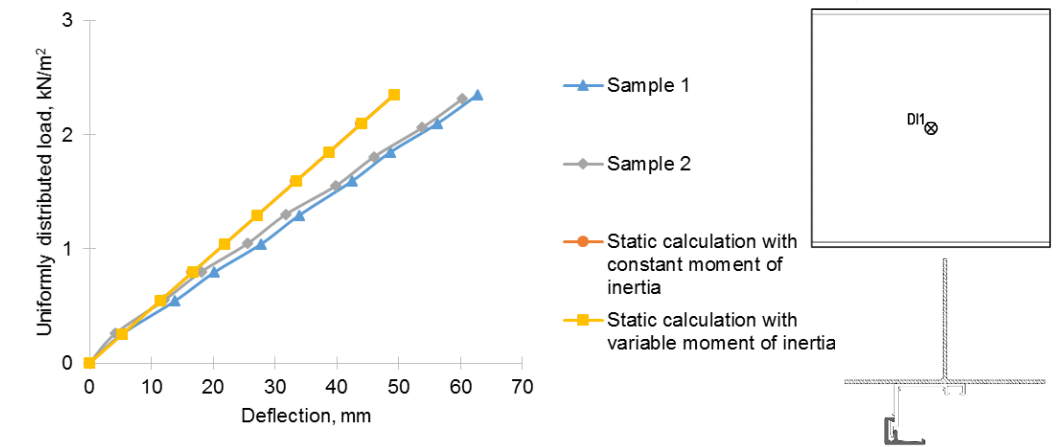

Figure 25. Deflection of the center of the panel (DI1).

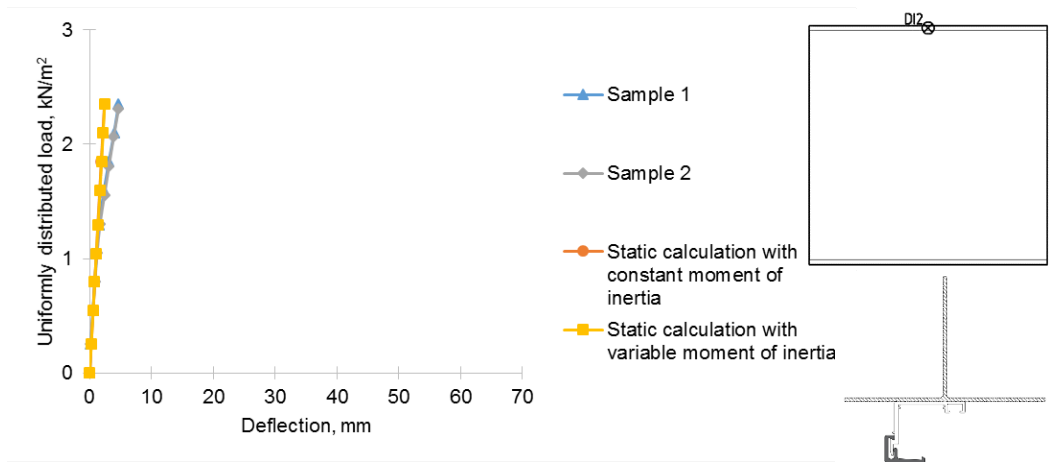

Figure 26. Deflection of the center of the frame (DI2).

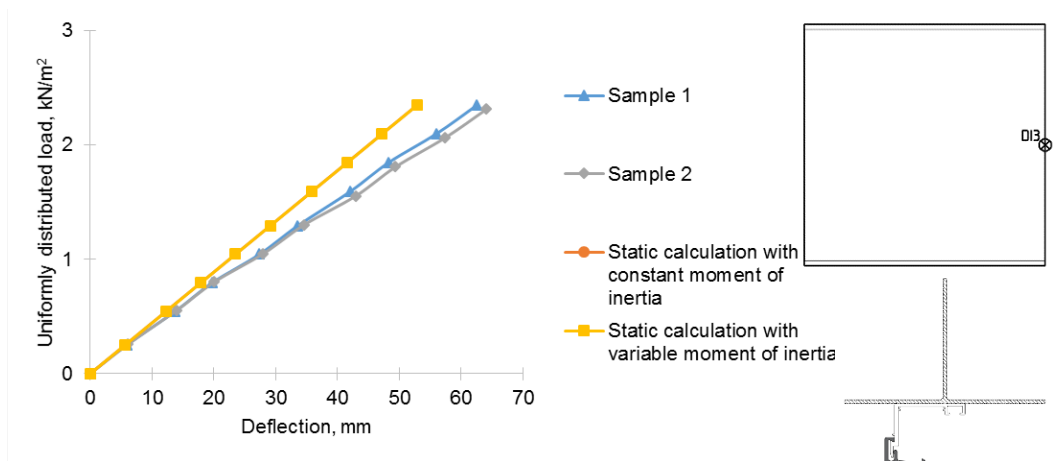

Figure 27. Deflection of the panel edge (DI3).

Graphs shown in Fig. 17, 20, 23 and 26 demonstrate that the results of static calculation are close to the experimental data until a certain value of uniformly distributed load, which depends on the stiffness of profile used in system. After exceeding this value mechanical behavior of the profile changes from linear to nonlinear. Additional discrepancy between experimental and numerical values is consequence of EPDM seal contribution to the overall performance of all investigated types of panels. In test setup 1 EPDM seal is subjected to crumpling in areas of point supports while it keeps its shape in the span. The EPDM seal remains elastic and recovers original shape after unloading. On the other hand, in test setup 2 crumpling occurs along the entire length of high-stiffness profile what leads to the displacement of starting point and increasing of experimental values. Since the national design codes set maximum allowable deflection for a structural element and not a system of elements (except the technological limitations), deflections of a glass panel can be preliminary estimated by static calculation in SJ Mepla.

During the design stage additional actions should be taken against the situation, in which the angle between the tangent to the curved axis of the panel and its initial position would exceed 10 degrees (see Fig. 28).

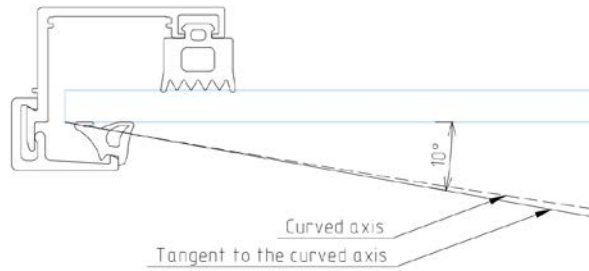

Figure 28. Curved axis of the panel and its tangent.



Figure 29. Deformation of sealant (test setup 1).

The total deflection of the system is supplemented by the deformation value of the rubber sealing profile. This phenomenon is observed in test setup 1 for parts of the system close to points of attachment to the bearing base, and, in the case of high rigidity frame profile (test setup 2), for the entire length of profile. Attention should be paid to the possible use of the system on the sections of facade where leakage may occur due to the deformation of the sealant.



Figure 30. Residual deformation of profile after unloading (test setup 1).

Aluminum profiles showed mechanical behavior in elastic zone at the stresses which did not exceed the yield strength of material. Example of residual deformation is shown in Fig. 29.

The solution of differential equation for the determination of deflection in case of plates with two parallel sides simply supported and the other two sides free is given in [30]. The adapted formula for the deflection of the center of the panel can be read as:

$$\omega = k \cdot 12(1 - \nu^2) \cdot \frac{q \cdot b^4}{E \cdot \delta^3}$$

where ω is a deflection of the panel, mm;

k is coefficient which characterizes the inclination of the graphs;

q is a value of uniformly distributed load, kN/m²;

b is a longer side of the panel, mm;

δ is a panel's thickness, mm;

E is a modulus of elasticity, GPa;

ν is a Poisson's ratio.

On the base of graphs in Fig. 16, 19, 22 and 25 (presenting the deflection in the center of the glass obtained from the calculation), following coefficients k were obtained:

Table 3. Coefficients k for determination of deflection in the center of the panel.

Scheme type	k
Test setup 1a	$5.064 \cdot 10^{-9}$
Test setup 2a	$2.927 \cdot 10^{-9}$
Test setup 1b	$1.589 \cdot 10^{-8}$
Test setup 2b	$1.344 \cdot 10^{-8}$

Thus, for preliminary determination of the deflection of the panels with configuration and dimensions close to the ones mentioned in this study, following formulas can be used:

$$\text{Test setup 1a: } \omega = 5.064 \cdot 10^{-9} \cdot \frac{q \cdot b^4}{D}$$

$$\text{Test setup 2a: } \omega = 2.927 \cdot 10^{-9} \cdot \frac{q \cdot b^4}{D}$$

$$\text{Test setup 1b: } \omega = 1.589 \cdot 10^{-8} \cdot \frac{q \cdot b^4}{D}$$

$$\text{Test setup 2b: } \omega = 1.344 \cdot 10^{-8} \cdot \frac{q \cdot b^4}{D}$$

where D is a cylindrical rigidity of the panel, N/m.

4. Conclusions

Experimental investigation and numerical modeling performed on the fragment of considered curtain wall system led to the following conclusions:

1. The values of deflection of the panels obtained during experimental study and numerical calculation in finite element software package show high similarity in the zone of linear elastic reaction of a system if specific boundary conditions emerging from the way of fixation of a panel to the system, such as rigidity of the compound aluminum frame, are accounted while calculating the glass panels.

2. Test results demonstrated that the loss of the bearing capacity of the system was caused by excessive deflection of the panel resulting in appearance of longitudinal forces, which led to displacement and subsequent fall of the rubber seal.

3. Empirical formulas for the analytical calculation of the panels with configuration and dimensions close to the ones mentioned in this study were proposed. They can be used in preliminary stages of design for estimation of the deflection in the center of the panel.

References

1. Roginska-Niesluchowska, M. Use of Daylight and Aesthetic Image of Glass Facades in Contemporary Buildings. Proceedings of IOP Conference Series: Materials Science and Engineering. Prague, 2017. 245(8). DOI: 10.1088/1757-899X/245/8/082035
2. Slaton, D. Challenges of modern materials: Assessment and repair. Journal of Architectural Conservation. 2017. 23(1–2). Pp. 47–61. DOI: 10.1080/13556207.2017.1312759
3. Pariafsai, F. A review of design considerations in glass buildings. Frontiers of Architectural Research. 2016. 5(2). Pp. 171–193. DOI: 10.1016/j.foar.2016.01.006
4. Jin, Q., Overend, M. A comparative study on high-performance glazing for office buildings. Intelligent Buildings International. 2017. 9(4). Pp. 181–203. DOI: 10.1080/17508975.2015.1130681
5. Kinowski, J., Sędlak, B., Sulik, P. Large glazing in curtain walls – Study on impact of fixing methods on fire resistance. MATEC Web of Conferences. 2016. No. 46. Article Number 05004. DOI: 10.1051/mateconf/20164605004

6. Bedon, C., Zhang, X., Santos, F., Honfi, D., Kozłowski, M., Arrigoni, M., Figuli, L., Lange, D. Performance of structural glass facades under extreme loads – Design methods, existing research, current issues and trends. *Construction and Building Materials*. 2018. No. 163. Pp. 921–937. DOI: 10.1016/j.conbuildmat.2017.12.153
7. Pérez-Grande, I., Meseguer, J., Alonso, G. Influence of glass properties on the performance of double-glazed facades. *Applied Thermal Engineering*. 2005. 25(17–18). Pp. 3163–3175. DOI: 10.1016/j.applthermaleng.2005.04.004
8. Atkins, C. Sustainability of glass in construction. Chapter of book: *Sustainability of Construction Materials*. 2009. Pp. 171–183. DOI: 10.1533/9781845695842.171
9. Wang, Y., Wang, Q., Sun, J., He, L., Liew, K.M. Effects of fixing point positions on thermal response of four point-supported glass façades. *Construction and Building Materials*. 2014. No. 73. Pp. 235–246. DOI: 10.1016/j.conbuildmat.2014.09.085
10. Bedon, C., Amadio, C. Buckling analysis and design proposal for 2-side supported double Insulated Glass Units (IGUs) in compression. *Engineering Structures*. 2018. No. 168. Pp. 23–34. DOI: 10.1016/j.engstruct.2018.04.055
11. Bernard, F., Daudeville, L. Point fixings in annealed and tempered glass structures: Modeling and optimization of bolted connections. *Engineering Structures*. 2009. 31(4). Pp. 946–955. DOI: 10.1016/J.ENGSTRUCT.2008.12.004
12. Chesnokov, A.G., Chesnokov, S.A., Krasnopolskij, B.I. Vliyanie sposoba zakrepleniya steklopaketov na prochnost stekol [Influence of the method of fixing double-glazed windows on the strength of glasses]. *Strojprofil*. 2006. 5(51). Pp. 110–114. (rus)
13. Baidjoe, Y., Van Lancker, B., Belis, J. Calculation methods of glass parapets in aluminium clamping profiles. *Glass Structures and Engineering*. 2018. 3(2). Pp. 321–334. DOI: 10.1007/s40940-018-0075-8
14. Leśniak, A., Górka, M. Analysis of the cost structure of aluminum and glass facades. *Proceedings of the 3rd International Conference on Engineering Sciences and Technologies: Advances and Trends in Engineering Sciences and Technologies. Tatranské Matliare*, 2018. Pp. 445–450.
15. Petritchenko, M.R., Kotov, E.V., Nemova, D.V., Tarasova, D.S., Sergeev, V.V. Numerical simulation of ventilated facades under extreme climate conditions. *Magazine of Civil Engineering*. 2018. 77(1). Pp. 130–140. DOI: 10.18720/MCE.77.12
16. Baiburin, A.Kh., Rybakov, M.M., Vatin, N.I. Heat loss through the window frames of buildings. *Magazine of Civil Engineering*. 2019. 85(1). Pp. 3–14. DOI: 10.18720/MCE.85.1
17. Rusanov, A.E., Baiburin, A. Kh., Baiburin, D.A., Bianco, V. Heat loss from defects of hinged facade systems of buildings. *Magazine of Civil Engineering*. 2020. 95(3). Pp. 57–65. DOI: 10.18720/MCE.95.6
18. Samarin, O.D. Temperature in linear elements of enclosing structures. *Magazine of Civil Engineering*. 2017. 70(2). Pp. 3–10. DOI: 10.5862/MCE.70.1
19. Samarin, O.D., Zaycev, N.N. Influencing of orientation of glazed facades on general energy consumption of residential buildings. *Magazine of Civil Engineering*. 2010. 18(8). Pp. 16–20. DOI: 10.18720/MCE.18.2. (rus)
20. Cwyl, M., Michalczyk, R., Grzegorzewska, N., Garbacz, A. Predicting performance of aluminum – Glass composite facade systems based on mechanical properties of the connection. *Periodica Polytechnica Civil Engineering*. 2018. 62(1). Pp. 259–266. DOI: 10.3311/PPci.9988
21. Drass, M., Kraus, M.A. Dimensioning of silicone adhesive joints: Eurocode-compliant, mesh-independent approach using the FEM. *Glass Structures and Engineering*. 2020. DOI: 10.1007/s40940-020-00128-4
22. Bäumlér, A., Müller, P. Experimental study on the tightness of glazing bead butt joints of aluminium windows considering comfort aspects. *Bauphysik*. 2014. 36(2). Pp. 74–79. DOI: 10.1002/bapi.201410020
23. Hagl, A. Experimental and numerical analysis of edge seal spacers of insulated glass units for structural sealant glazing applications. *Proceedings of Challenging Glass 3: Conference on Architectural and Structural Applications of Glass. Delft*, 2012. Pp. 221–234. DOI: 10.3233/978-1-61499-061-1-221
24. Rosendahl, P.L., Staudt, Y., Schneider, A.P., Schneider, J., Becker, W. Nonlinear elastic finite fracture mechanics: Modeling mixed-mode crack nucleation in structural glazing silicone sealants. *Materials and Design*. 2019. No. 182. DOI: 10.1016/j.matdes.2019.108057
25. Silvestru, V.A., Enghardt, O., Schneider, J. Linear adhesive connections at the edge of laminated glass panes: an experimental study under tensile, compressive and shear loading. *Glass Structures and Engineering*. 2019. 4(1). Pp. 45–68. DOI: 10.1007/s40940-018-0080-y
26. Machalická, K., Vokáč, M., Kostecká, M., Eliášová, M. Structural behavior of double-lap shear adhesive joints with metal substrates under humid conditions. *International Journal of Mechanics and Materials in Design*. 2019. 15(1). Pp. 61–76. DOI: 10.1007/s10999-018-9404-y
27. Wallau, W., Recknagel, C. Test methodology for performance assessment of structural sealant glazing systems at superimposed mechanical and climatic loading. *Polymer Testing*. 2019. No. 79. DOI: 10.1016/j.polymertesting.2019.106030
28. Galyamichev, A.V. Vetrovaja nagruzka i ejo dejstvie na fasadnye konstrukcii [Wind load and its action on facade structures]. *Construction of Unique Buildings and Structures*. 2017. 60(9). Pp. 44–57. DOI: 10.18720/CUBS.60.4. (rus)
29. Galyamichev, A.V., Alkhimenko, A.I. Design features of facade cassettes from thin ceramics. *Magazine of Civil Engineering*. 2017. 69(1). Pp. 64–76. DOI: 10.18720/MCE.69.6
30. Vainberg, D.V., Vainberg, E.D. Raschet plastin [Design of plates]. *Budivelnik*. Kiev, 1970. 436 p. (rus)

Contacts:

Ekaterina Gerasimova, katyageras17@gmail.com

Alexander Galyamichev, gav@spbstu.ru

Gregor Schwind, schwind@ismd.tu-darmstadt.de

Jens Schneider, schneider@ismd.tu-darmstadt.de